

# OEM pressure transducer

## With high accuracy

### Models TIS-20, TIS-21

WIKA data sheet PE 81.68

## Applications

Basis for:

- Sensor integration projects with high demands on measurement technology
- Process transmitters

## Special features

- Digital output signal (UART)
- Accuracy up to 0.06 %
- Turndown up to 20:1 possible
- ATEX and IECEx component approval



OEM pressure transducer

## Description

### Optimal basis

The model TIS-2x OEM pressure transducer, due to the accuracy it achieves, serves as the basis for high-quality pressure measuring instruments with high accuracy requirements.

### Individual designs

As standard, a variety of versions with respect to process connection and mechanical connection to a case already exist.

On request, further customisations can be realised in order to meet your technical requirements.

### Thinking to the future

The component approval in explosion protection, digital interface and high level of in-house production at WIKA ensure availability and usability of the TIS-2x for the future.

### Technical aspects

The TIS-2x maintains the high accuracy of up to 0.06 % over the temperature range of 10 ... 70 °C.

The instrument can be adjusted using turndown to the desired pressure range by the customer.

## Measuring ranges

Gauge pressure							
bar	0 ... 0.4	0 ... 1	0 ... 1.6	0 ... 2.5	0 ... 4	0 ... 6	0 ... 10
	0 ... 16	0 ... 25	0 ... 40	0 ... 60	0 ... 100	0 ... 160	0 ... 250
	0 ... 400	0 ... 600	0 ... 1,000 <sup>1)</sup>				
psi	0 ... 10	0 ... 15	0 ... 20	0 ... 30	0 ... 50	0 ... 100	0 ... 150
	0 ... 200	0 ... 300	0 ... 500	0 ... 700	0 ... 1,000	0 ... 1,500	0 ... 2,000
	0 ... 3,000	0 ... 5,000	0 ... 6,000	0 ... 10,000 <sup>1)</sup>			

1) Not possible with flush process connection

Absolute pressure							
bar	0 ... 0.4	0 ... 1	0 ... 1.6	0 ... 2.5	0 ... 4	0 ... 6	0 ... 10
	0 ... 16	0 ... 25	0 ... 40				
psi	0 ... 10	0 ... 15	0 ... 20	0 ... 30	0 ... 50	0 ... 100	0 ... 150
	0 ... 200	0 ... 300	0 ... 500				

Vacuum and +/- measuring range							
bar	-1 ... 0	-1 ... +0.6	-1 ... +1.5	-1 ... +3	-1 ... +5	-1 ... +10	-1 ... +15
	-1 ... +25	-1 ... +40	-0.1 ... +0.3	-0.2 ... +0.2	-0.5 ... +0.5		

### Overpressure limit

Measuring range  $\leq$  25 bar / 300 psi: 3-fold

Measuring range  $>$  25 bar / 300 psi: 2-fold

### Vacuum tightness

Yes (except for oxygen version)

## Output signal

Digital output signal, UART

## Voltage supply

### Power supply

DC 3.4 ... 3.8 V

### Power consumption

max. 5 mW (with power supply 3.5 V)

Low power consumption on request.

## Accuracy specifications

### Accuracy per IEC 60770 at reference conditions (maximum measuring deviation)

Measuring range	Accuracy
< 1 bar	0.15 %
≥ 1 ... < 1.6 bar	0.10 %
≥ 1.6 ... ≤ 40 bar	0.06 %
> 40 bar	0.08 %

The values refer to the standard materials. Values for special alloys and coatings on request.

### Behaviour with turndown (TD)

Measuring span ≥ 1.6 bar

■ Turndown ≤ 5:1	no effect
■ Turndown > 5:1 ... ≤ 20:1	Accuracy + (TD - 5) · 0.015 %

Measuring span < 1.6 bar

■ Turndown > 1:1 ... ≤ 20:1	Accuracy + (TD - 1) · 0.015 %
-----------------------------	-------------------------------

After turndown, a zero adjustment must be carried out.

### Non-linearity following terminal method (IEC-61298-2)

max. 0.05 % FS for turndown 1:1 to 5:1

### Long-term drift

Measuring range	Accuracy
< 1 bar	max. 0.35 % of span/year
≥ 1 ... < 1.6 bar	max. 0.15 % of span/year
≥ 1.6 ... ≤ 40 bar	max. 0.10 % of span/year
> 40 bar	max. 0.05 % of span/year

### Measurement temperature range (per DIN 16086)

-20 ... +80 °C

Ambient temperature range in which the specification limits are not exceeded.

### Mean temperature coefficient

Temperature	Zero point	Span
-20 ... +10 °C	0.1 %/10 K	0.1 %/10 K
10 ... 70 °C	No additional temperature error <sup>1)</sup>	
70 ... 80 °C	0.1 %/10 K	0.1 %/10 K

<sup>1)</sup> without turndown; accuracy specifications at reference conditions are maintained

## Time response

### Switch-on time

max. 1 second till the first valid measured value

### Refresh rate

New measured value after 20 ms (at 38,400 baud)

## Operating conditions

### Permissible temperature ranges

Ambient temperature ranges, within which the instrument may be operated without permanent changes of its metrological properties.

Permissible temperature ranges	
Ambient	-40 ... +80 °C
Storage	-50 ... +85 °C
Medium	
■ Standard operation	-40 ... +85 °C
■ Limited ambient temperature	-40 ... +105 °C
■ With cooling element	-40 ... +150 °C
■ Oxygen version	-20 ... +60 °C
■ Food-compatible version	-20 ... +85 °C

## Reference conditions (per IEC 61298-1)

### Temperature

15 ... 25 °C

### Atmospheric pressure

860 ... 1,060 mbar

### Humidity

45 ... 75 % relative

### Power supply

DC 3.5 V

### Mounting position

Calibrated in vertical mounting position with process connection facing downwards.

## Process connections

Selectable versions	
Standard	Thread size
EN 837	G 3/8 B
	G 1/2 B
	M20 x 1.5
ANSI/ASME B1.20.1	1/4 NPT
	1/2 NPT
	1/2 NPT, female
-	G 1/2 B, flush
	G 1 B, flush
	G 1 1/2 B, flush
Hygienic	G 1 hygienic, flush
	G 1 hygienic, flush, with cooling element

## Materials

### Process connections

Process connection	Material
Standard process connection	
■ Measuring range ≤ 40 bar / 500 psi	316L
■ Measuring range > 40 bar / 500 psi	316L and 2.4711
Flush process connection	316L

### Pressure transmission medium

Process connection	Material
Standard process connection	
■ Measuring range ≤ 40 bar / 500 psi	Synthetic oil <sup>1)</sup>
■ Measuring range > 40 bar / 500 psi	Dry measuring cell
Flush process connection	Synthetic oil <sup>2)</sup>

1) Special filling for oxygen applications  
 2) Special filling with food approval

## Electrical connection

JST connector SHR-0.4V  
 others on request

## Dimensions in mm

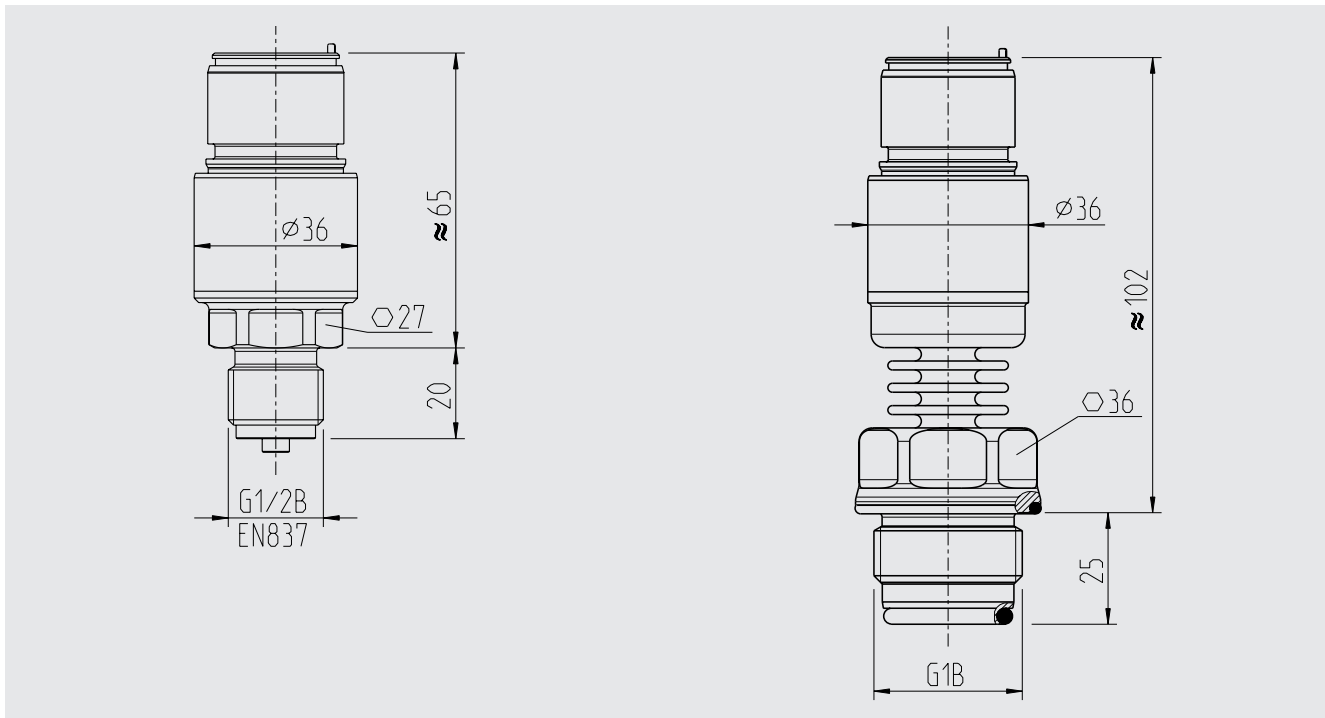

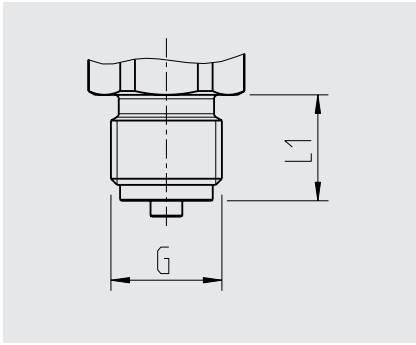

G	L1
G 3/8 B	16
G 1/2 B	20
M20 x 1.5	20

Hexagon dimension: 12 mm  
Spanner width: 27

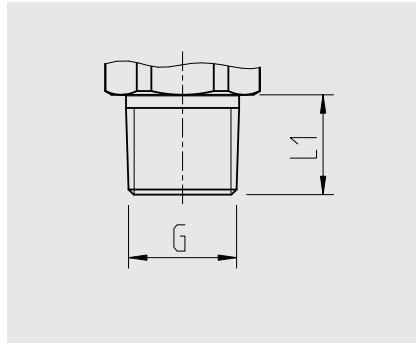

G	L1
1/4 NPT	13
1/2 NPT	19

Hexagon dimension: 12 mm  
Spanner width: 27

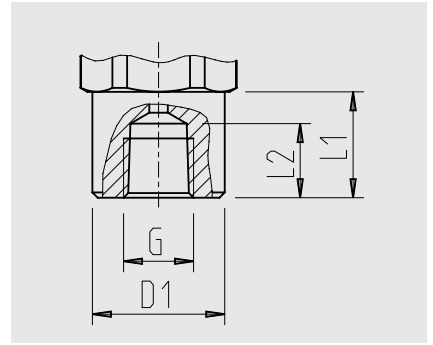

G	L1	L2	D1
1/2 NPT, female	20	19	26.5

Hexagon dimension: 12 mm  
Spanner width: 27

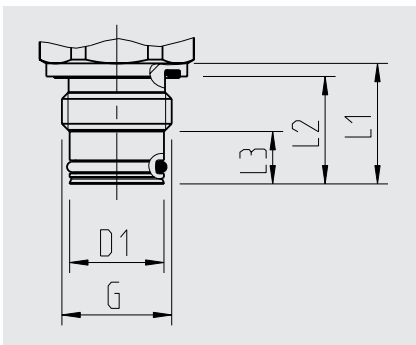

G	L1	L2	L3	D1
G 1/2 B	23	20.5	10	18

Hexagon dimension: 12 mm  
Spanner width: 27

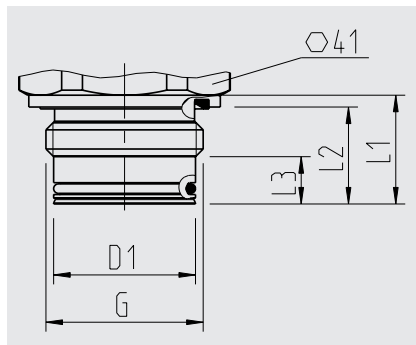

G	L1	L2	L3	D1
G 1 B	23	20.5	10	30

Hexagon dimension: 13 mm

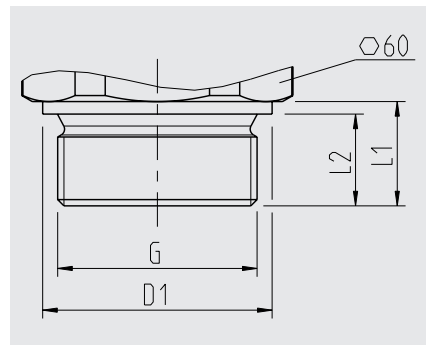

G	L1	L2	D1
G 1 1/2 B	25	22	55

Hexagon dimension: 14 mm

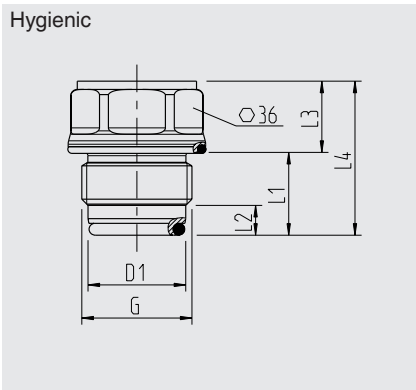

G	L1	L2	L3	L4	D1
G 1 B	25	9	19	46.5	29.5

Hexagon dimension: 13 mm

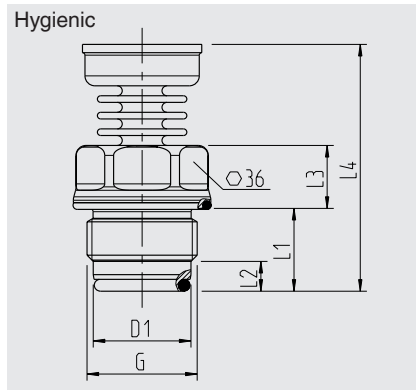

G	L1	L2	L3	L4	D1
G 1 B	25	9	19	74.5	29.5

Hexagon dimension: 13 mm

© 2016 WIKA Alexander Wiegand SE & Co. KG, all rights reserved.  
The specifications given in this document represent the state of engineering at the time of publishing.  
We reserve the right to make modifications to the specifications and materials.

