

# OEM pressure transducer With signal processing Model TI-1

WIKA data sheet PE 81.57

## Applications

- Integration into data loggers, pressure controllers and hand-helds
- Basis for pressure transmitters

## Special features

- Digital or analogue output signals
- Non-linearity of up to 0.125 % of span
- Measuring range: 0 ... 0.4 to 0 ... 1,000 bar
- Common international process connections



Examples of the model TI-1 OEM pressure transducer

## Description

### Optimal basis

The model TI-1 pressure transducer serves as the core for the widest variety of products such as pressure transmitters, data loggers, pressure controllers or as components in hand-held measuring instruments.

WIKA uses the TI-1 as the basis of pressure measuring instruments for the highest industrial requirements. This guarantees a security of supply over many years.

As a customer, you profit from our long experience in the field of sensor manufacturing and compensation.

### State-of-the-art manufacturing

The pressure transducer is manufactured on state-of-the-art production equipment, enabling the greatest flexibility and fast lead times. The manufacturing concept offers continuous traceability for each produced unit, down to an individual component level.

### Individual designs

A wide range of designs in the area of process connections and mechanical connections to the case is already available.

On request, further customisations can be developed in order to meet customer demands to the full extent.

### Technical aspects

As output signals, digital signals such as UART, I<sup>2</sup>C and SPI or an analogue voltage signal are available.

Via the digital interface, the sensor unit can provide a wide range of information, e.g. the sensor temperature.

Following assembly, a zero adjustment and span correction can be carried out.

## Measuring ranges

Gauge pressure							
bar	0 ... 0.4	0 ... 0.6	0 ... 1	0 ... 1.6	0 ... 2.5	0 ... 4	0 ... 6
	0 ... 10	0 ... 16	0 ... 25	0 ... 40	0 ... 60	0 ... 100	0 ... 160
	0 ... 250	0 ... 400	0 ... 600	0 ... 1,000			
psi	0 ... 10	0 ... 15	0 ... 25	0 ... 30	0 ... 50	0 ... 60	0 ... 100
	0 ... 150	0 ... 160	0 ... 200	0 ... 250	0 ... 300	0 ... 400	0 ... 500
	0 ... 600	0 ... 750	0 ... 1,000	0 ... 1,500	0 ... 2,000	0 ... 3,000	0 ... 4,000
	0 ... 5,000	0 ... 6,000	0 ... 7,500	0 ... 10,000	0 ... 15,000		

Absolute pressure							
bar	0 ... 0.4	0 ... 0.6	0 ... 1	0 ... 1.6	0 ... 2.5	0 ... 4	0 ... 6
	0 ... 10	0 ... 16					
psi	0 ... 10	0 ... 15	0 ... 25	0 ... 30	0 ... 50	0 ... 60	0 ... 100
	0 ... 150	0 ... 160	0 ... 200	0 ... 250	0 ... 300	0 ... 400	0 ... 500

Vacuum and +/- measuring ranges							
bar	-0.4 ... 0	-0.6 ... 0	-1 ... 0	-1 ... +0.6	-1 ... 1.5	-1 ... +3	-1 ... +5
	-1 ... +9	-1 ... +15	-1 ... +24	-1 ... +39	-1 ... +59		
psi	-30 inHg ... 0	-30 inHg ... +15	-30 inHg ... +30	-30 inHg ... +45	-30 inHg ... +60	-30 inHg ... +100	-30 inHg ... +160
	-30 inHg ... +200	-30 inHg ... +300	-30 inHg ... +500				

Other measuring ranges on request.

### Overpressure limit

The overpressure limit is based on the sensor element used. Depending on the selected process connection and sealing, restrictions in overpressure safety can result. A higher overpressure limit will result in a higher temperature error.

Selectable versions		
Measuring range	< 10 bar (150 psi)	≥ 10 bar (150 psi)
Standard	3 times	2 times
Option	5 times	3 times

1) Restriction: max. 60 bar (870 psi) with absolute pressure.

2) Only possible for gauge pressure measuring ranges ≤ 400 bar (5,800 psi).

3) Only possible for absolute pressure measuring ranges < 16 bar (220 psi).

## Output signals

Selectable versions	
Digital	I <sup>2</sup> C SPI UART Switching output
Analogue	DC 0.3 ... 2.7 V

### Vacuum tightness

Yes

## Voltage supply

### Power supply

#### Selectable versions

Standard	DC 3 V $\pm$ 1 %
Option	DC 2.7...3.6 V (has influence on the overall accuracy)

### Current supply

SPI: 2.7 mA (typ.), 3.7 mA (max.)

I<sup>2</sup>C: 2.7 mA (typ.), 3.7 mA (max.)

UART: 2.1 mA (typ.), 3 mA (max.)

Voltage/switching signal: 2.8 mA (typ.), 3.7 mA (max.)

## Accuracy specifications

The values given are only valid for the listed measuring ranges.

### Non-linearity (per IEC 61298-2)

$\leq \pm 0.125$  % of span (BFSL)

$\leq \pm 0.25$  % of span (terminal method)

### Accuracy at reference conditions

$\leq \pm 0.25$  % of span

### Long-term drift (per IEC 61298-2)

$\leq 0.1$  % of span

$\leq 0.2$  % of span (measuring ranges < 1 bar)

### Zero adjustment and span correction

Zero point:  $\pm 0$  ... 20 %

Span:  $\pm 0$  ... 20 %

### Temperature measurement

Measuring error between -30 ... +100 °C

4 K (typ.), 12 K (max.)

### Temperature error

For measuring ranges < 1 bar, special measuring ranges and instruments with an increased overpressure limit the respective temperature error increases by 0.5 % of span

## Reference conditions (per IEC 61298-1)

### Temperature

15 ... 25 °C

### Atmospheric pressure

860 ... 1,060 mbar

### Humidity

45 ... 75 % r. h.

### Power supply

DC 3 V

### Mounting position

Calibrated in vertical mounting position with pressure connection facing downwards.

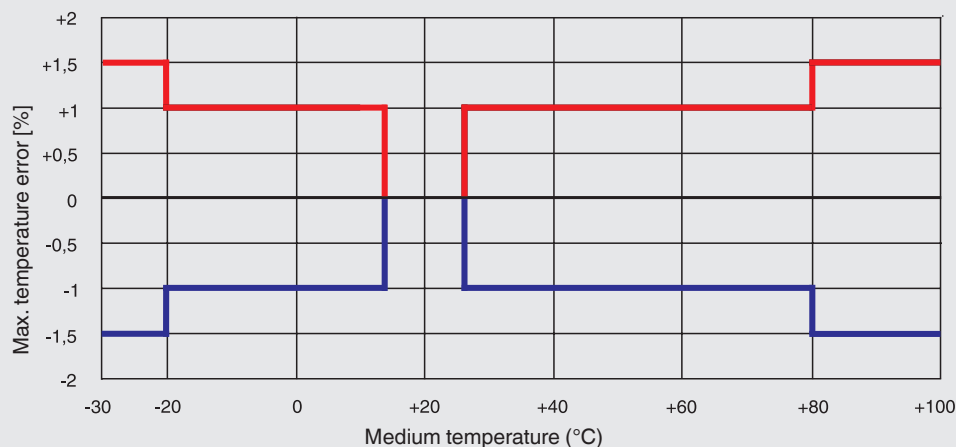

## Operating conditions

### Permissible ambient temperature

-40 ... +125 °C

Depending on the sealing on the process connection and the electrical connection, there may be limitations in the medium and ambient temperatures.

## Process connections

Various process connections on request

## Electrical connection

### Electrical connection

ERNI - Microstac 0.8 mm Mezzanine connector system

Others on request

### Pin assignment

Pin	Description	UART	SPI	I <sup>2</sup> C
X1.1	Chip-select	-	CS	-
X1.2	Serial clock	-	-	-
X1.3	Master out slave in	-	-	-
X1.4	Master in slave out	-	-	-
X1.5	Serial clock	-	SCLK	SCL
X1.6	Serial data	-	MOSI	SDA
X2.1	Analogue supply voltage	AVDD	AVDD	AVDD
X2.2	Analogue/digital ground	GND	GND	GND
X2.3	Digital supply voltage	DVDD	DVDD	DVDD
X2.4	GPIO/DAC	Voltage or switching signal <sup>1)</sup>	MISO	-
X2.5	Serial UART transmit	TxD	-	-
X2.6	Serial UART receive	RxD	-	-

1) Optional

## Dimensions in mm

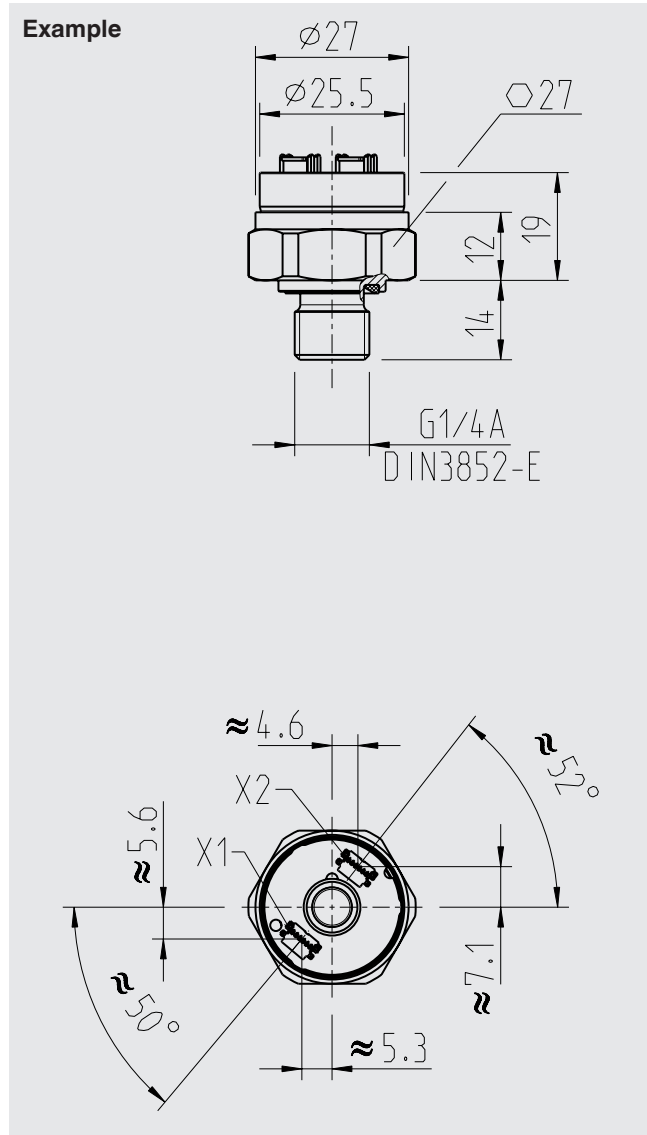

## Manufacturer's declaration

RoHS  
2011/65/EU

## Ordering information

Measuring range / Overpressure limit / Power supply / Output signal / Process connection

© 2015 WIKA Alexander Wiegand SE & Co. KG, all rights reserved.  
The specifications given in this document represent the state of engineering at the time of publishing.  
We reserve the right to make modifications to the specifications and materials.



**WIKAI Alexander Wiegand SE & Co. KG**  
Alexander-Wiegand-Straße 30  
63911 Klingenberg/Germany  
Tel. +49 9372 132-0  
Fax +49 9372 132-406  
info@wika.de  
www.wika.de